



PFS shown with optional ZK830

DESCRIPTION

General

Take the scale to the job rather than the job to the scale.

Design

- › 24" x 18" - 1,000 lb deck scale
- › Designed to interface with a ZK Series parts counting scale.
- › Standard 12" x 14" platform with pre-drilled holes to mount a battery operated counting scale or an indicator.
- › Includes mounting hardware to hold a ZK Series parts counting scale or ZM indicator.
- › Includes DB9 connector to interface with a ZK Series parts counting scale.

SPECIFICATIONS

GENERAL

Capacity	1,000 lb (500 kg)
Finish	Carbon steel, high grade powder paint finish
Weight Sensor	(1) 350-ohm shear beam load cell
Load Cell Output	2mV/V
Overload Protection	200%
End Loading	100%
Accuracy	0.02% of rated output
Temperature	14° F to 104° F / -10° C to 40° C
Load Cell Cable	10 ft cable included inside column
Wheels	Polyolefin, each wheel capacity rated at 300 lbs

PFS PORTABLE FLOOR SCALE

Technical Specification

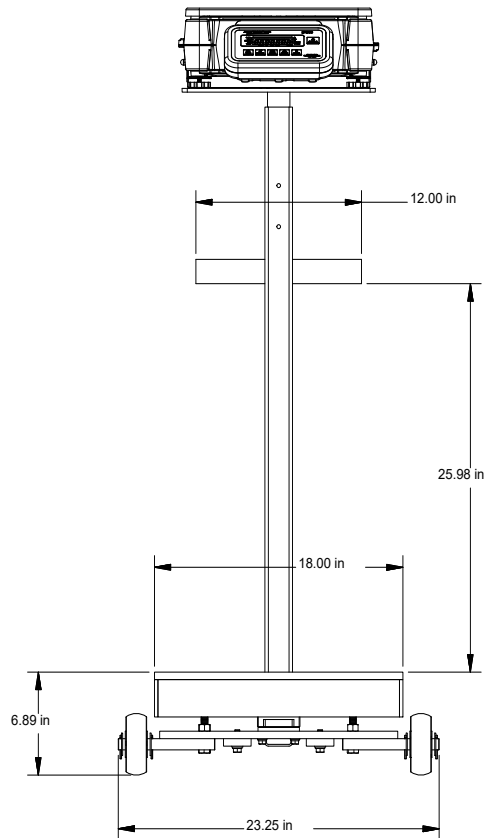
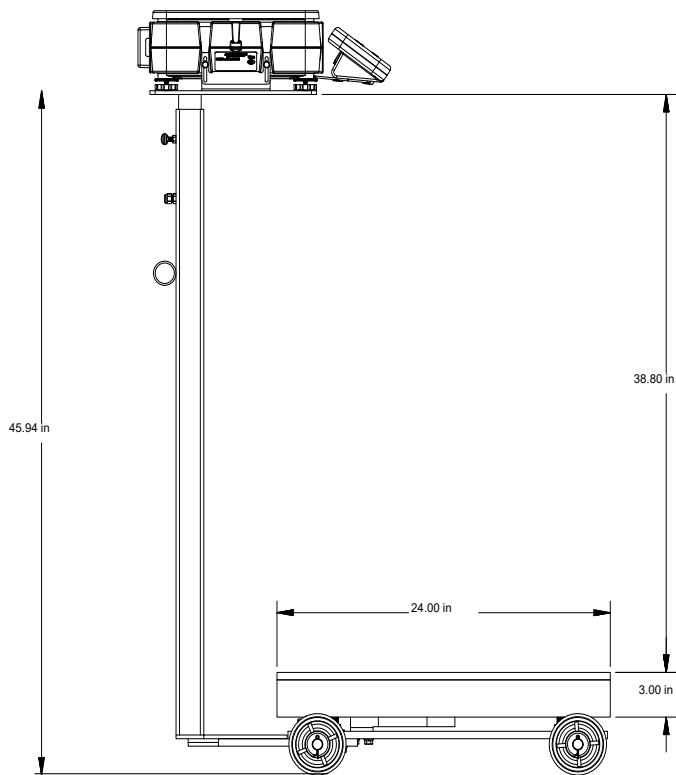
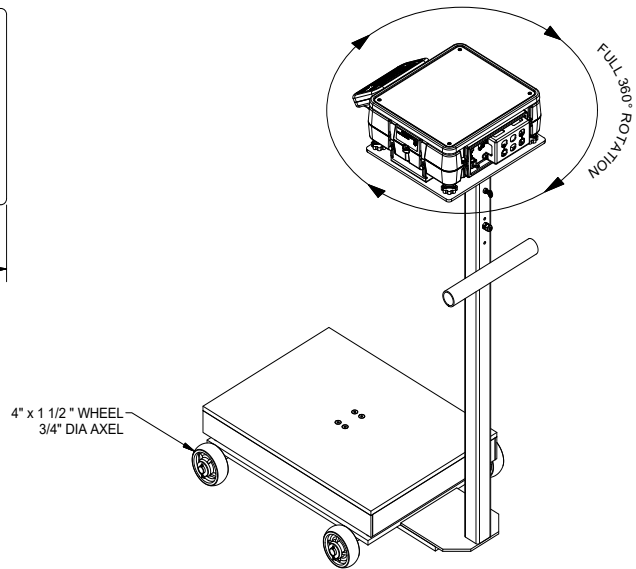
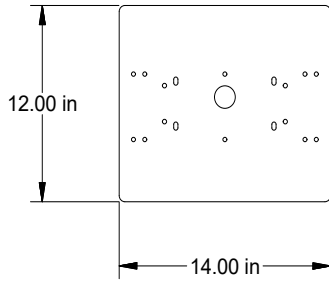

Avery Weigh-Tronix

www.averyweigh-tronix.com

Avery Weigh-Tronix is an ITW company



Avery Weigh-Tronix is a trademark of the Illinois Tool Works group of companies whose ultimate parent company is Illinois Tool Works Inc ("Illinois Tool Works"). Copyright © 2019 Illinois Tool Works. All rights reserved. This publication is issued to provide outline information only and may not be regarded as a representation relating to the products or services concerned. This publication was correct at the time of going to print, however Avery Weigh-Tronix reserves the right to alter without notice the specification, design, price or conditions of supply of any product or service at any time.

PFS_spec_500473.indd
V3 AWT35-500473