



The OHAUS Scout[®] Pro – Hands Down The Industry's Best Portable Balance!

Designed for use in laboratory, industrial or education applications, the OHAUS Scout *Pro* features easy-to-use two-button operation, a high-contrast LCD display, multiple weighing units, four application modes, and the option of either RS232 or USB connectivity, the Scout *Pro* is the portable balance for your needs!

- **Maximum Protection** – Scout *Pro* is designed with mechanical and software protection against shock and overloading which can cause damage to the weighing cell. An integrated shipping lock protects the weighing cell during transportation or storage
- **RS232 or USB Connectivity** – Scout *Pro* interface accessories are easy to install at anytime, even after purchase. The data cable is integrated in the kit, eliminating the need for additional cables
- **Multiple Application Modes** – Scout *Pro* features Enhanced Parts Counting, Percent Weighing, Totalization and Display Hold

Scout® Pro Portable Electronic Balances

Built-In Application Modes:

Parts Counting – The Scout Pro is designed for counting parts for inventory control, parts bagging, receiving, dispensing and ticket counting

- Select from a sample size of 5, 10, 20 or 50 pieces while in counting mode with a quick button press
- The Scout Pro features user-enabled automatic recalculation of the average piece weight – instead of counting 100 parts for a sample, count 10 and let the Scout Pro count the rest of the sample! For applications where automatic recalculation is not desired, the easy-to-use menu system allows this feature to be disabled
- The Scout Pro can also be configured for situations where only the counting feature is required



Percent Weighing – Use the *Percent Weighing* mode to compare samples for compounding, formulation, or quick weight checking. Place your reference weight on the platform, enter the weight into memory, and the display will show the percentage of the sample weight on the platform compared to the reference weight.

Totalization – Use the Scout Pro's memory function to repeatedly sum the weight on the platform for compounding and formulation. Unlike other balances, the Scout Pro allows totalization up to the limit of the display!

Display Hold – The *Display Hold* mode allows you to retain the weight of an over-sized package on the Scout Pro's display. Great for postal and shipping applications!

User-Configurable – The Scout Pro allows you to select active weighing units and modes using the two-button keypad. Scout Pro can be quickly configured using an on-display menu system – there are *no* cryptic codes to input! A built-in lockswitch prevents reconfiguration during use.

New Design for Portable or Benchtop Use



Scout Pro with Square Platform
(6.5 x 5.5 in / 16.5 x 14.2 cm)

600g x 0.1g
2000g x 0.1g
4000g x 0.1g
6000g x 0.1g
6000g x 1g



Scout Pro with Round Platform
(4.7 in / 12 cm diameter)

200g x 0.01g
400g x 0.01g
600g x 0.01g
400g x 0.1g

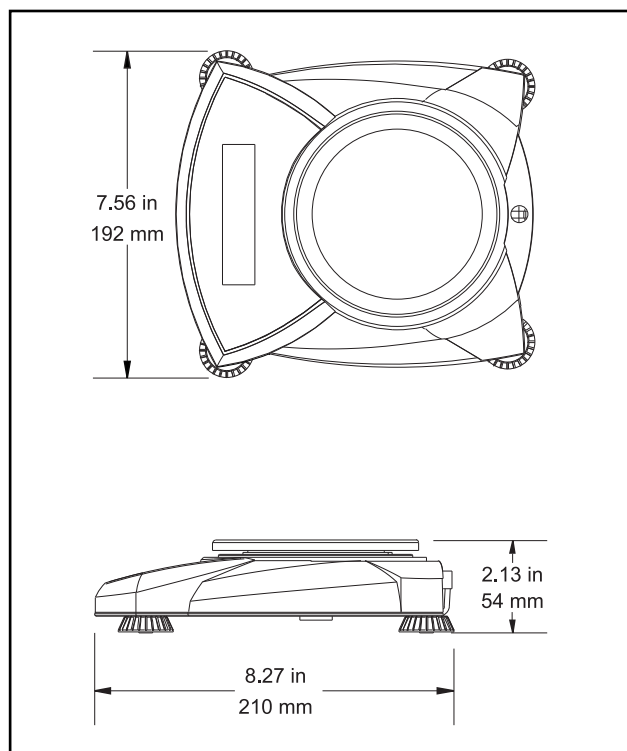

Ohaus Scout Pro: Models and Weighing Units for Every Application.

- Parts Counting and Bagging
- Animal/Egg Weighing
- Feed Dispensing
- Medical Output Studies
- Crop and Seed Analysis
- Paint, Ink, Dye and Glaze Formulation
- Compound Preparation and Packaging
- Dental Adhesive and Compound Formulation
- Education Experiments
- Field Studies
- Parts Inventory, Quality Control and Receiving
- Filter Analysis
- Testing Kits
- Sample Gathering and Field Testing
- Food Portioning and Packaging
- Catering and Restaurant Applications
- Diet and Portion Control
- Jewelry Stores and Pawn Shops
- Injection Molding Sampling
- Shipping and Receiving
- Racquet and Golf Club Balancing
- Ticket Counting

The Scout Pro features the most common weighing units required for use in the lab, on the shop floor, or in the field:

- Grams
- Kilograms
- Ounces
- Pounds
- Troy Ounces
- Pennyweights
- Combined Pound:Ounce display

Scout Pro Unit Availability

Model	SP202	SP402	SP602	SP401	SP601	SP2001	SP4001	SP6001	SP6000
Capacity	200g	400g	600g	400g	600g	2000g	4000g	6000g	6000g
Readability	0.01g	0.01g	0.01g	0.1g	0.1g	0.1g	0.1g	0.1g	1g
g	Yes	Yes	Yes	Yes	Yes	Yes	Yes	Yes	Yes
kg	–	–	–	–	–	Yes	Yes	Yes	Yes
oz	Yes	Yes	Yes	Yes	Yes	Yes	Yes	Yes	Yes
lb	–	–	Yes	–	Yes	Yes	Yes	Yes	Yes
lb:oz	–	–	Yes	–	Yes	Yes	Yes	Yes	Yes
ozt	Yes	Yes	Yes	Yes	Yes	Yes	Yes	Yes	Yes
dwt	Yes	Yes	Yes	Yes	Yes	Yes	Yes	Yes	Yes

Connectivity

An Ohaus first, you can quickly add either an internal RS232 or a USB port with integrated cable to the Scout Pro



Security Bracket

Each Scout Pro features an integrated security bracket to prevent theft



Flexible Power

Use either the included AC wallpack, or 4 "AA" batteries to power your Scout Pro

Round or Square Stainless Steel Platform

Removable for easy cleaning

Easy-to-Clean

Sealed front panel and molded spill ring

Integral Shipping Lock

Quickly accessible under the weighing pan, the shipping lock allows you to lock and go!



Easy to View

High-Contrast LCD quickly displays weight and applications data, as well as an indicator for stability, over/underload conditions, and low battery power

Lockswitch

The Scout Pro can be locked into a specific configuration using the included lockswitch



Weigh-Below Hook

The integral weigh-below-hook on the bottom of the Scout Pro allows density determination or calculating the specific gravity of samples



